

MX40G E-O Converter: De-Embedding Procedures

INTRODUCTION

An electrical-to-electrical (E-E) vector network analyzer (VNA) measures the response of an electrical system as a function of frequency. The simplest measurement of an E-E system connected between Ports 1 and 2 of the VNA is a “through” measurement, which provides the magnitude and phase response of the E-E system measured in the normal forward direction. This measurement is usually reported by the VNA in the S_{21} section of an S-parameter file, which gives the magnitude and phase response of the device for each frequency measurement point in the range of interest. When the E-E system consists only of an E-E device under test (DUT), the response of the E-E DUT is the same as the E-E system response. In this application note, the measured through response of the E-E system is referred to as the $EE_{S_{21}}$ data.

Measuring the optical-to-electrical (O-E) DUT’s through response, referred to here as $OE_{S_{21}}$, using an E-E VNA requires a calibrated E-O converter such as the MX40G. The MX40G is placed between Port 1 of the E-E VNA and the O-E DUT to convert the electrical output of the VNA into an optical signal. This is coupled into the O-E DUT, and the electrical output signal of the O-E DUT is measured directly using Port 2 of the VNA. In this case, the E-E system response measured by the VNA consists of the MX40G electrical-to-optical (E-O) converter’s response, referred to here as $EO_{S_{21}}$, combined with the O-E DUT’s.

To de-embed the response of the O-E DUT, $OE_{S_{21}}$, one must remove the response of the MX40G (E-O) converter, $EO_{S_{21}}$, from the E-E system response measured by the VNA, $EE_{S_{21}}$. This can be done in many ways and depends on the type of response information required and available math processing capabilities.

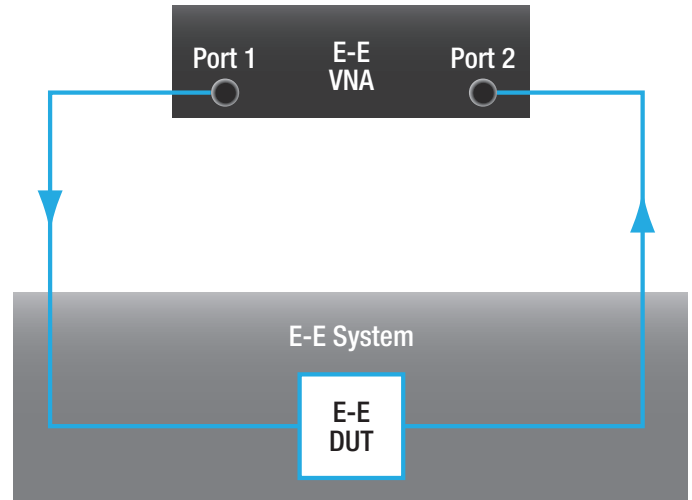

$EE_{S_{21}}$ is the through response of the E-E DUT.

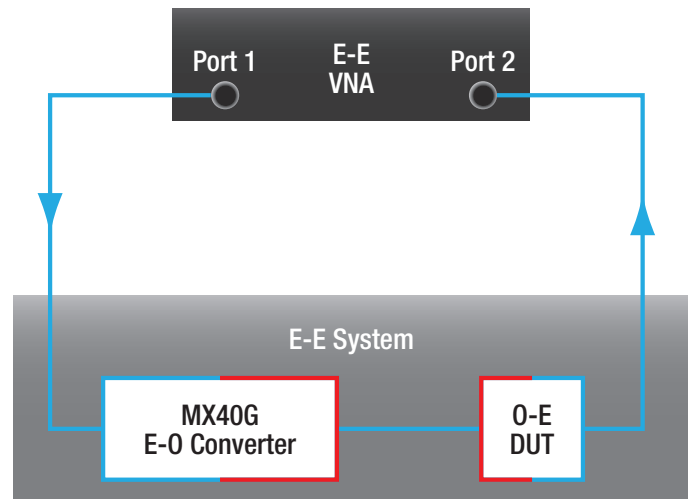

$EE_{S_{21}}$ is the combined through responses of the MX40G, $EO_{S_{21}}$, and the O-E DUT, $OE_{S_{21}}$.

THE S-PARAMETER (S2P) FILE

Thorlabs provides the through response of the MX40G E-O converter, $EO_{S_{21}}$, in a standard S-parameter file format, which is the most common way of providing frequency response data of a device or system. The standard file format has nine columns of CSV or tab-delimited values.

- ◆ The first row (#) contains information about the data types contained in the file. The “MA” in this row indicates that the file contains linear magnitude (M) and angle (A) data.
- ◆ The second row is a comment line that labels the column content for the user. The file may contain several comment type lines.
- ◆ The first column lists the frequency measurement points in GHz. The length of the table is determined by the frequency range and resolution.
- ◆ The second through ninth columns contain S-parameters measured at the stated frequency.

Measurements of the through response of the MX40G are contained in columns S21M and S21A. Column S21M provides the linear magnitude response, and column S21A provides the phase angle response in degrees.

The uncertainty in the magnitude response values, at every specified frequency from 40 MHz to 40 GHz, is ± 0.85 dB.

Unlike the S-parameter file supplied with the MX40G, the S-parameter file of the E-E system response measured by the VNA, $EE_{S_{21}}$, will typically have non-zero values in all columns. But even when the other columns are populated with measurement data, it is valid to extract the S_{21} through response data for use in calculations.

#	GHz	S	MA	R	50			
! Freq	S11M	S11A	S21M	S21A	S12M	S12A	S22M	S22A
0.035	0	0	1.135	-175.641	0	0	0	0
0.435	0	0	1.001	-43.959	0	0	0	0
0.834	0	0	1.022	90.295	0	0	0	0
1.234	0	0	1.001	-136.689	0	0	0	0
1.634	0	0	0.976	-2.953	0	0	0	0
2.033	0	0	0.988	132.458	0	0	0	0
2.433	0	0	0.973	-93.219	0	0	0	0
2.833	0	0	0.951	41.345	0	0	0	0
3.232	0	0	0.952	175.929	0	0	0	0
3.632	0	0	0.951	-49.286	0	0	0	0
4.032	0	0	0.944	85.399	0	0	0	0
4.431	0	0	0.946	-140.484	0	0	0	0
4.831	0	0	0.932	-6.091	0	0	0	0
5.230	0	0	0.917	128.145	0	0	0	0

Sample S2P File Values from MX40G Data

DE-EMBEDDING PROCEDURES

De-embedding requires removing the response of the E-O converter, $EO_{S_{21}}$, from the E-E system response measured by the VNA, $EE_{S_{21}}$. The de-embedding calculations can be performed by the VNA or performed manually. In the following sections, it is assumed that the through response data of the E-O converter and E-E system are available as the S_{21} portions of S-parameter files.

Using VNA Instrument Functionality

It is common to configure VNAs equipped with de-embedding functionality to automatically perform the de-embedding procedure. This requires loading the S2P S-parameter response file (*.s2p) of the E-O converter into the VNA. The S2P file is supplied with the MX40G. When the VNA is configured to de-embed using an external file, the corrected result (i.e. the isolated response of the O-E DUT) will be displayed on the VNA's screen. Please consult the manual of the VNA for information on implementing this procedure; it usually requires assigning de-embedding to Port 1 and placing the MX40G between Port 1 and the O-E DUT. The VNA accepts S2P files with data expressed in different units, and the VNA has the ability to interpolate data when the $EE_{S_{21}}$ and $EO_{S_{21}}$ data are measured at different frequency points.

Performing De-Embedding Calculations Manually

If the VNA is not equipped with de-embedding functionality, the calculations described in the following can be performed manually using the S_{21} data. The more complex calculations required for complete 2-port S-parameter de-embedding, which uses transmitted as well as reflected response data measured at both ports, is beyond the scope of this application note. Complete 2-port S-Parameter de-embedding is useful when the interactions among the devices are more complex.

The through response de-embedding calculations remove the response of the E-O converter, $EO_{S_{21}}$,

from the measured E-E system response, $EE_{S_{21}}$, to yield the response of the O-E DUT, $OE_{S_{21}}$. The structure and contents of the supplied S2P file containing the through response of the E-O converter are described in the table on page 1. A pair of magnitude and angle values are provided for each frequency point. The S21M magnitude data in this file have linear units, unless they are specifically noted to have units of dB. The S21A phase angle data are in degrees, unless they are noted to be in radians.

Using i as the row index, a given frequency value is referred to here as $FREQ(i)$. The S_{21} magnitude and angle values measured for the E-E system at this frequency point are called $EE_{S_{21}M}(i)$ and $EE_{S_{21}A}(i)$, respectively. The respective values corresponding to the same frequency point for the E-O converter are referred to as $EO_{S_{21}M}(i)$ and $EO_{S_{21}A}(i)$. The calculations described below are performed using the values at every frequency value of interest, and they yield the magnitude and angle values for the O-E DUT: $OE_{S_{21}M}(i)$ and $OE_{S_{21}A}(i)$, respectively.

The de-embedding calculations require the E-E system and the E-O converter data to have the same units. The linear magnitude data supplied in the S2P file for the E-O converter can be expressed in units of dB by calculating

$$20 \log_{10}(EO_{S_{21}M}(i)) \quad (1)$$

for all frequency measurement points. It is customary to plot response data with units of dB.

Note that it is also necessary for the S_{21} response data of the E-E system and the E-O converter to be referenced to the same frequency measurement points. If this is not the case, the data should be interpolated so that both files have magnitude and angle data at the same frequency measurement points.

Equations for calculating the magnitude and angle response of the O-E DUT are as follows:

Magnitude Values with Linear Units:

$$OE_{S_{21}}M(i) = EE_{S_{21}}M(i) / EO_{S_{21}}M(i) \quad (2)$$

Magnitude Values with Units of dB:

$$OE_{S_{21}}M(i) = EE_{S_{21}}M(i) - EO_{S_{21}}M(i) \quad (3)$$

Angle Values with Units of Degrees or Radians:

$$OE_{S_{21}}A(i) = EE_{S_{21}}A(i) - EO_{S_{21}}A(i) \quad (4)$$

Standard spreadsheet software is a convenient and effective tool for performing manual mathematical de-embedding. In the following example, all magnitude data have units of dB. This required converting the linear magnitude $OE_{S_{21}}M$ data to decibels using Equation (1). The table below shows the S_{21} values in spreadsheet form.

The first column lists the index values, the second shows frequency measurement points, the next two contain the $EE_{S_{21}}$ magnitude and angle data measured by the VNA, and the following two contain $EO_{S_{21}}$ data extracted from the E-O converter's provided S2P file. The last two columns are the magnitude and angle $OE_{S_{21}}$ response data calculated using Equations (3) and (4), respectively. Note that the $EO_{S_{21}}$ data are usually normalized to 0 dB at some low frequency value, which in this example is 1 GHz. This results in the corrected DUT response changing relative to the normalization point. After calculating these data, they can then be plotted and viewed directly in the spreadsheet.

Index	Frequency (GHz)	EE_S21 (Measured)		EO_S21 (Provided)		OE_S21 (Calculated)	
		Magnitude (dB)	Angle	Magnitude (dB)	Angle	Magnitude (dB)	Angle
i	FREQ(i)	EE_S21M(i)	EE_S21A(i)	EO_S21M(i)	EO_S21A(i)	OE_S21M(i)	OE_S21A(i)
1	0.035	-22.270	176.243	1.1	-175.641	-23.370	351.884
2	0.435	-23.350	-100.484	0.009	-43.959	-23.359	-56.525
3	0.834	-23.098	-14.811	0.189	90.295	-23.287	-105.106
4	1.234	-23.350	67.643	0.009	-136.689	-23.359	204.332
5	1.634	-23.609	151.25	-0.211	-2.953	-23.398	154.203
6	2.033	-23.479	-124.127	-0.105	132.458	-23.374	-256.585
7	2.433	-23.742	-39.953	-0.238	-93.219	-23.504	53.266
8	2.833	-23.876	41.164	-0.436	41.345	-23.440	-0.181
9	3.232	-23.876	124.952	-0.427	175.929	-23.449	-50.977
10	3.632	-23.876	-151.332	-0.436	-49.286	-23.440	-102.046
11	4.032	-24.013	-67.581	-0.501	85.399	-23.513	-152.980
12	4.431	-24.013	16.298	-0.482	-140.484	-23.531	156.782
13	4.831	-24.152	99.464	-0.612	-6.091	-23.540	105.555
14	5.230	-24.293	-177.104	-0.753	128.145	-23.541	-305.249

Sample S_{21} Values in Spreadsheet Form. Columns from left to right are: index values, frequency measurement points, $EE_{S_{21}}$ data measured by VNA, $EO_{S_{21}}$ data extracted from provided S2P file, $OE_{S_{21}}$ response calculations.

S₂₁ Magnitude Response

